

Simulation of the Purification Process of Waste Cooking Oil as a Feedstock for Biodiesel Production

Miguel A. Guerrero-Muñoz, Karla E. Mares-Molina, José J. Tovar-Negrete, Salvador Hernández, Fabricio O. Barroso-Muñoz *

Department of Chemical Engineering, DCNE, Universidad de Guanajuato, Noria Alta, s/n, Col. Noria Alta, Guanajuato, Gto., CP. 36050, México.

faobamu@ugto.mx

In the present work, the simulation of the purification process of waste cooking oil (WCO) as feedstock for biodiesel production was simulated using Aspen Plus™ V11.0. The process was simulated considering the compositions of the waste cooking oils in the central region of Mexico, specifically in the center of the state of Guanajuato. The equipment necessary to separate the ash and organic food waste were considered in the process simulation. It is necessary to consider that waste cooking oil contains a large amount of free fatty acids, which could cause saponification in the case of using the basic route to produce biodiesel. Kinetic model and thermodynamics model were taken from literature. As initial part of the process simulation a decanter was included. Therefore, the process was simulated to reduce the amount of free fatty acids and remotion or ashes and water from waste cooking oil. Finally, the purified oil contains, less than 1% by weight of free fatty acids, which makes it ideal for producing biodiesel by basic transesterification or any other route for biodiesel production. These results were consistent with the experimental results reported in the literature.

1. Introduction

Biodiesel, a mixture of fatty methyl/ethyl esters derived from plant/animal triglycerides through transesterification with an alcohol, is a fuel that is under a great deal of consideration. It has been assessed that biodiesel yields 93% more energy than that invested in its production, and relative to fossil fuels, greenhouse gases are reduced 41% by biodiesel production and combustion while less air pollutants are released per net energy gain. Although these benefits are very attractive, the current biodiesel final cost is prohibitively high without governmental subsidies (Cossio-Vargas et al. 2011). Fossil fuels currently cover 82% of the world's population's energy needs. In addition, greenhouse gas emissions increased by 5.7% in 2021. Maintaining this energy model will lead to the depletion of the few reserves available in a few years. For this reason, several alternatives have been proposed, among them biofuels, which in 2021 had an increase in global production of 4.1% and their consumption increased by 7.6% (British Petroleum, 2022), making them a promising source for the substitution of fossil fuels. However, biofuel production in Mexico has not exceeded 500 BEP/d and its consumption has grown from 2000 to 4000 BEP/d in the last 10 years. Biodiesel is defined as a mixture of long-chain monoalkyl esters of fatty acids from catalytic transesterification with short-chain alcohols, such as methanol and ethanol. It is considered as a potential substitute for conventional diesel (Osorio-Canul et al. 2019). The most widely used method to produce biodiesel is transesterification, which can be basic, acidic, or enzymatic. In general, to produce biodiesel, the oil is mixed with alcohol in a certain ratio and the catalyst is added inside a reactor at a certain temperature. As it was mentioned, when basic catalytic route for producing biodiesel is used, the amount of free fatty acid is relevant to avoid saponification. Therefore, it is important to reduce free fatty acid. Their concentration must be less than 1 wt%. Further, the alcohol is then recovered and recirculated into the process. At the end of the reaction, the mixture undergoes liquid-liquid extraction with glycerol to separate the biodiesel.

1.1 Catalyst

As it was mentioned before, it is required a catalyst. It can be basic, acidic, or enzymatic. Using a catalyst in the transesterification reaction helps the alcohol to better dissolve with the oil phase. Something relevant is that the oil (especially if residual), to be used in biodiesel production, must have a free fatty acid (FFA) content below 1% by weight to avoid saponification when using an alkaline catalyst to achieve high yield and purity. It is well known that waste cooking oil have a free fatty acid content higher than 1% (Grosmann et al. 2022).

The acid catalytic process avoids saponification even though the oil used contains a large amount of FFA. However, a separation and purification step are required, the reaction time is longer, and the temperature required is higher.

An alternative is to have a pretreatment stage (esterification) using an acid catalyst that converts the FFA into esters. In this way, transesterification can be carried out using a base to convert triglycerides to esters, without the risk of forming soap in the process. The disadvantage is that it can be costly as it requires separation of the catalyst, purification of the methyl esters, corrosion, and high energy consumption (Elias et al. 2020).

1.2 Environmental and economic issues

Although WCO is also used in the manufacture of soaps and in the oleochemical industry, it still is a relevant raw material for biodiesel production (Sheinbaum-Pardo et al. 2013). Many studies report that the properties of biodiesel are comparable to those of petroleum diesel, which makes it to be considered as an alternative energy source. Waste cooking oil is one of the most viable sources for biodiesel production. In addition to being economical, it reduces the costs associated with its disposal as waste. According to several studies, the yield when using ACU is like that obtained with virgin oil (higher than 90%) The large amount of water and free fatty acids in used cooking oil makes the production of biodiesel using this feedstock difficult.

Approximately 70-80% of the cost of biodiesel production is associated with the cost of the raw material, which could be reduced by up to 60-70% if waste cooking oil is used. It is important to mention that in Mexico, there is not a specific regulation for disposal of the waste cooking oil. Therefore, there is a latent environmental problem regarding the disposal of waste cooking oil, since in many cases this oil is disposed of directly into the sewage system. This degrades water quality and causes serious health problems. The use of this oil as feedstock for biodiesel production, could help mitigate water contamination, as well as reduce the blockage of drainage systems. In this way it could help to decrease the disposal process of this waste raw material, and partially help to satisfy the world's energy demand.

2. Methodology

2.1 Raw material composition

The process simulation software ASPEN Plus V10.0 software was used to simulate the used cooking oil purification process. As mentioned above, the objective of this work was to simulate the process to provide a possible solution to the disposal and use of this waste in the central region of Mexico, specifically in the state of Guanajuato. The main oils used in the region were investigated, as well as the final composition of the oil after it is used for cooking. One liter of WCO is 85% oil, 10% water and 5% organic matter and its composition is reported in Table 1. The ash derived from the cooking processes was also included. Usually, this residual component it is not included in some similar simulation.

Table 1. Composition of WCO.

Component	Mass Fraction
Triolein	0.7184
Dirolein	0.0309
Monolein	0.0063
Oleic Acid	0.0801
Linoleic Acid	0.0325
Palmitic Acid	0.0119
Esteric Acid	0.009
Water	0.11
Ash	0.0009

The procedure to carry out the simulation mainly involves the definition of the chemical components required in the chemical process to be simulated, the suitable choice of the thermodynamic model and choosing the required operating units and their operating conditions.

Information of most components such as water, glycerol, methanol, oleic acid was included in the Aspen library. However, other components such as ash, triolein, diolein and monoolein, calcium carbonate and sodium hydroxide as well as their properties were defined using the corresponding tool included in ASPEN Plus V10.

2.2 Thermodynamic model

Because the presence of methanol and glycerol which are highly polar components, the thermodynamic model used was UNIFAC-Dortmund, due to its ability to properly represent the lipid mixture, ELV and ELL equilibria of methanol-biodiesel and methanol-glycerol blends, as well as to predict the solubility of water in biodiesel. (Zhang et al. 2003).

2.3 Process Simulation

The simulated process includes reactors, extraction and distillation columns, pumps, and heat exchangers. The process simulated involves only the esterification of the FFA (Equation 1) for being used as oil for producing biodiesel as well neutralization reactor. Regarding the esterification reaction, the corresponding kinetic information is shown in Table 2 (Jansri et al. 2011).



Table 2. Kinetics parameters

Reaction	K (l/mol min)	Ea (cal/mol)
Direct	1.34	17997
Reverse	0.682	129

Remotion of ash and water

The process flowsheet is shown in Figure 1. It is relevant to mention that waste cooking oil contains ashes (food residues) produced during the frying food process. Therefore, it is important to remove them before the WCO be introduced to the purification process for avoiding consequent operational problems. The purification process starts feeding 1000 kg/h of WCO to a decanter to remove water and ash from the oil. Water and ashes removed from decanter as secondary stream is sent to disposal procedure. As it was mentioned previously, it is no usual that ash derived from the cooking processes remotion of ash and water be included as part of process simulation. However, the authors consider important to simulate this part of the process as well the equipment used for remotion.

While oil stream free of these two components (A-ACID2) is sent to an esterification reactor (R-ESTER) operating at 60 °C and 1 atm. Also, a second stream of methanol and sulfuric acid is fed to this reactor to carry out the esterification process.

The esterification reaction was carried out according to kinetic data shown in Table 2.

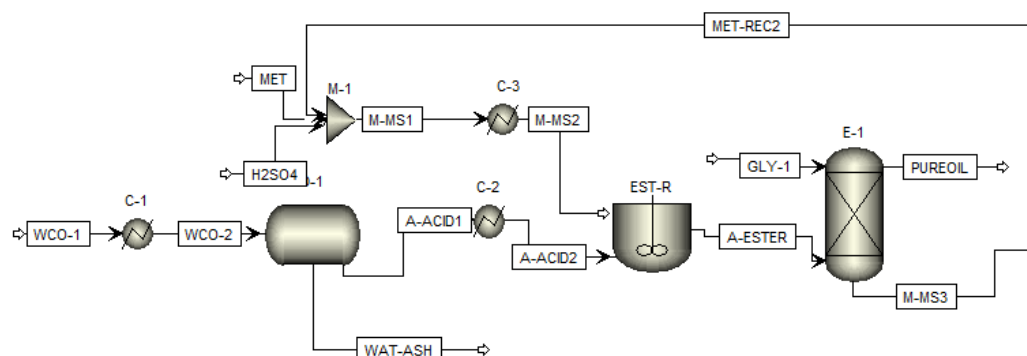

Figure 1. Purification process of WCO flowsheet (esterification process)

Oil purification and neutralization steps

It is important to emphasize that the next operation equipment is very important, because the outlet stream from the esterification reactor was fed to a 6-stage liquid-liquid extraction column (E-1). This extraction column was designed to operating 45°C and 5 atm, using glycerol as entrainer with a flow rate of 120 kg/h.

From the dome of the extraction column, an outlet stream with a composition of FFA less than 1% by weight is ready to undergo a subsequent transesterification reaction. Now, this oil is ready to be used to produce biodiesel by basic catalytic process. However, bottom stream must be processed for separating methanol, glycerol, etc.

Methanol recuperation

However, from the bottom of the extraction column, a stream (M-MS3) containing glycerol and catalyst mainly, passes through a neutralization reactor (R-NEU) Figure 2. For simulating neutralization reaction, a RStoic reactor module in ASPEN was used, considering the stoichiometry of the neutralization reaction. It is important to mention that RStoic module is a stoichiometric reactor, which reacts according to the measurement relationship in the chemical reaction equation to obtain the material balance of the reactor. The neutralization reaction is representing in Equation 2.



The stream leaving the reactor (PRO-NEU) is fed to a filter (FILTER) to remove the salt produced in the neutralization reaction.

The liquid stream (LIQ-1) from filter is fed to a distillation column operating with 25 stages to recover as much methanol as possible and recirculated to the esterification reactor.

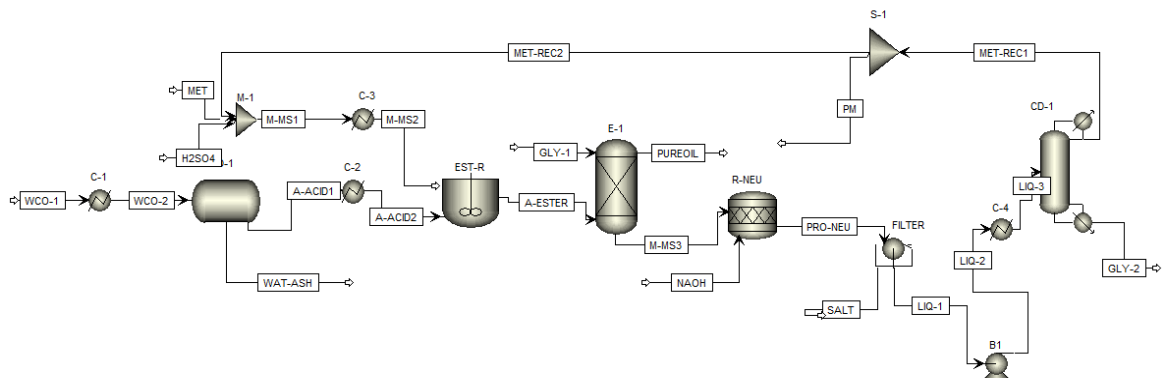

Figure 2. Purification process of WCO flowsheet (including methanol recuperation)

3. Results

Remotion of ash and water

According to simulation, at the beginning of the simulated process, it was possible to eliminate all the ashes contained in the WCO before esterification stage using a decanter. It can be seen in Table 3.

Table 3. Stream composition for remotion of ash and water.

Component (kg/h)	WCO-2	A-ACID2
Water	110.00	1.68
Ash	0.90	0.00

Oil purification and neutralization steps

The streams from extraction column M-MS3 and PURE OIL are shown in Table 4.

Table 4. Stream composition for purification of WCO process

Component (kg/h)	A-ESTER	PURE OIL	PRO-NEU
Triolein	718.40	718.40	0.00
Diolein	30.90	30.90	0.00
Monoolein	6.30	5.84	0.46
Oleic Acid	5.38	5.37	0.01
Linoleic Acid	2.18	2.18	0.01
Palmitic Acid	0.80	0.80	0.00
Steric Acid	0.60	0.60	0.00
Methanol	138.73	0.01	138.71
Water	9.72	0.00	12.48
H ₂ SO ₄	7.49	0.00	0.00
Methyl-ol	78.43	78.41	0.02
Methyl-pa	11.71	11.70	0.01
Methyl-li	31.83	31.82	0.01
Methyl-st	8.81	8.81	0.00
Glycerol	0.00	0.08	119.92

Methanol recuperation

According to Figure 2, recuperation and methanol purification is carried out in distillation column DC-1. The result for streams for methanol recuperation are shown in Table 5.

Table 5. Mass fraction composition for methanol recuperation

Component (kg/h)	GLY-2	MET-REC1
Methanol	0.006	0.99
Water	0.092	0.0001
Glycerol	0.89	0.00

According to Table 3, the organic matter was eliminated, while some traces of water remained (0.19 wt.%). The FFA content in the oil before esterification is 15%, which is very high, but after esterification it was reduced to 1%, so it is within the limit. The oil that comes out of the extraction column has a purity of 99.99%, It is worth mentioning that here also all the sulfuric acid was removed from the bottom stream of the extraction column.

The purification yield of WCO was 89.5%, this value is like that reported in some previous papers. Finally, in this process 99.38% of the methanol that entered the distillation column was recovered. After esterification, the oil has a content of 0.85% by weight FFA and 14.83 wt.% impurities (water, H₂SO₄ and methanol). However, this percentage was reduced after purification.

4. Conclusions

The goal of this project was to simulate a conventional process for using waste cooking oil as raw material for diminishing environmental impact and diminishing cost of biodiesel production in the central part of the state of Guanajuato, México. It could be used as a local solution for small business generation. As well as conceptual basis for scaling up to satisfy local demand. It was included ash and water remotion process. This step should not be ignored, because ashes could produce malfunction to equipment downstream. The result shows that it is possible to reach a free fatty acid composition lower than 1wt%. It is important to mention that it is necessary an economic analysis in order to compare with other processes. It is worth mentioning that the processes simulated at a later stage could be optimized using rigorous optimization techniques, to obtain the best configuration in terms of equipment design, solvent flows, energy consumption, and cost.

Nomenclature

FFA – Free Fatty Acid

WCO – Waste cooking oil

Methyl-ol – Methyl oleate

Methyl-pa – Methyl palmitate

Methyl-li - Methyl linoleate

Methyl-st - Methyl stearate

Acknowledgments

The authors acknowledge to Universidad de Guanajuato for supporting this project.

References

- British Petroleum. (2022). Statistical Review of World Energy 2022 <<https://www.bp.com/content/dam/bp/businesssites/en/global/corporate/pdfs/energy-economics/statistical-review/bp-stats-review-2022-full-report.pdf>> accessed 12.07.2023
- Cossio-Vargas, E., Hernandez, S., Segovia-Hernandez, J.G. and Cano-Rodriguez, M.I., 2011. Simulation study of the production of biodiesel using feedstock mixtures of fatty acids in complex reactive distillation columns. *Energy* 36, 6289-6297.
- Elias, S., Rabiú, A.M., Okeleye, B.I., Okudoh, V. and Oyekola, O. 2020. Bifunctional Heterogeneous Catalyst for Biodiesel Production from Waste Vegetable Oil. In *Applied Sciences*.
- Grosmann, M.T., Andrade, T.A., Bitonto, L.D., Pastore, C., Corazza, M.L., Tronci, S. and Errico, M., 2022. Hydrated metal salt pretreatment and alkali catalyzed reactive distillation: A two-step production of waste cooking oil biodiesel. *Chemical Engineering and Processing - Process Intensification* 176, 108980.
- Jansri, S., Ratanawilai, S.B., Allen, M.L. and Prateepchaikul, G., 2011. Kinetics of methyl ester production from mixed crude palm oil by using acid-alkali catalyst. *Fuel Processing Technology* 92, 1543-1548.
- Osorio-Canul, M., García-Magallanes, G., Herrera-Lugo, A. and Novelo-Moo, T., 2019. Propuesta de producción de biodiésel mediante aceite vegetal usado. *Revista de Energías Renovables*.
- Sheinbaum-Pardo, C., Calderón-Irazoque, A. and Ramírez-Suárez, M., 2013. Potential of biodiesel from waste cooking oil in Mexico. *Biomass and Bioenergy* 56, 230-238.
- Zhang, Y., Dubé, M.A., Mclean, D.D. and Kates, M., 2003. Biodiesel production from waste cooking oil: 1. Process design and technological assessment. *Bioresource Technology* 89, 1-16.